

The BelGAS^{CP} P5300 is a backpressure regulator with an integrally mounted pilot. Except where liquid or very low gas pressure is involved, upstream gas is used to operate this unit.

Applications

- Separators
- Heater Treaters
- Compressor Stations
- Gas Gathering Systems

Features

- NACE Construction: All BelGAS^{CP} P5300 backpressure regulators are built in accordance with the requirements of NACE MR0-175.
- Intermittent Acting Pilot
- Soft Seat Material for Bubble Tight Shut-off
- High Capacity

Materials of Construction

Part	Material
Bonnet	Ductile Iron
Upper Housing	Ductile Iron
Middle Housing	Ductile Iron
Lower Housing	Ductile Iron
Main Body	Ductile Iron
Upper Diaphragm	Polyurethane or Fluorocarbon
Middle Diaphragm	Nitrile or Fluorocarbon
Main Diaphragm	Nitrile or Fluorocarbon
Orifices	Stainless Steel
Tubing/Fittings	Stainless Steel



Specifications

Design Pressure	300 PSIG	
Media	Gas and Air	
End Connections	2" NPT	
Temperature	Nitrile	-20 to 180°F (-28.9 to 82.2°C)
	Flurocarbon	0 to 300°F (-5 to 204°C)
	AFLAS	25 to 400°F (-5 to 204°C)
	HSN	-55 to 300°F (-48 to 150°C)

P5300 Part Number Matrix

	P53	00	16	S	D	T	0		N	12
Style										
Backpressure Valve		00								
Body Size										
2"			16							
End Connection										
Female NPT				S						
Casing Material										
Ductile Iron					D					
Body Style										
Globe (180 degree)						T				
Seat Material - Elastomer Material										
Buna-N - Polyurethane									0	
Fluorocarbon - Polyurethane									2	
HSN									5	
FEPM									6	
Construction										
NACE										N
Pressure Range										
5-125 PSI										12
10-300 PSI										30

Dimensional Data (in.)

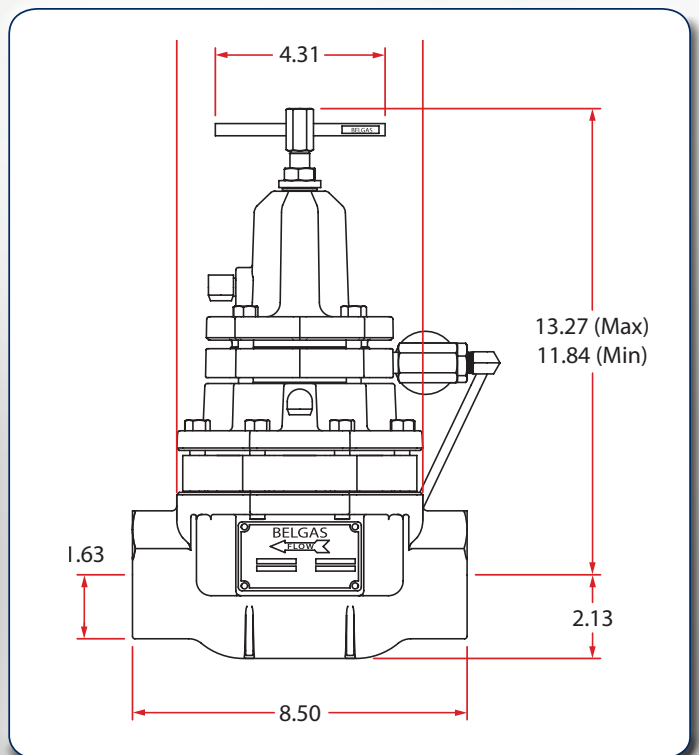

P5300 Parts List & Repair Kits

Item	Description	Qty.	Part Number
1	T-Handle Adjustment Screw Subassembly	1	803-077-000
2	Hex Jam Nut	1	634-185-001
3	Washer	1	662-236-003
4	Sealing Washer	1	662-245-000
5	Spring Plate 300 PSIG	2	638-095-000
	Spring Plate 5-125 PSIG		638-119-000
6	Main Spring 10-300 PSIG	1	655-797-000
	Main Spring		655-815-000
7	Bonnet	1	604-278-000
8	Vent	3	836-004-000
9	Upper Diaphragm Plate	1	638-094-000
10	Upper Diaphragm	Polyurethane	618-115-000
		FKM	618-115-001
		FEPM	618-115-002
		HSN	618-115-003
11	Diaphragm Nut	1	634-219-000
12	Upper Housing	1	629-261-000
13	Middle Diaphragm	Nitrile	618-114-000
		FKM	618-114-001
		FEPM	618-114-002
		HSN	618-114-003
14	Middle Housing	1	629-262-000
15	Hex Cap Screw	12	648-467-012
16	Main Diaphragm	Nitrile	600-520-000
		FKM	600-520-001
		FEPM	600-520-002
		HSN	600-520-003
17	Lower Housing	1	629-263-000
18	Housing Spacer	1	607-315-000
19	Body Gasket	1	624-116-000
20	2" NPT Iron Body	1	664-590-000
21	1/4" NPT Plug	1	639-099-000
22	Seat Retainer	1	643-227-000
23	Valve Spring	1	655-786-001
24	Pilot Seat	1	650-197-000
25	Pilot Plug	1	813-053-001
26	Pressure Gauge	1	GG15300C8SSM-001
27	Elbow Compression Fitting	2	622-079-001
28	Bleed Orifice Gasket	1	624-115-000
29	Bleed Orifice	1	688-077-001
30	Pilot Supply Tubing	1	660-236-000
31	Diaphragm Plate	1	638-096-000
32	Retaining Ring	1	693-036-000
33	Bushing	1	608-091-000
34	O-ring	Nitrile	649-000-150
		FKM	649-000-338
		FEPM	649-351-007
		HSN	649-437-002
35	Backup Ring	2	649-347-000
36	Valve Stem	1	651-113-000
37	Seat Holder	1	650-206-000
38	Main Seat	Nitrile	649-346-000
		FKM	649-346-001
		FEPM	649-346-002
		HSN	649-346-002
39	Orifice Gasket	1	624-117-000
40	Main Orifice	1	688-078-000
41	Locknut	1	634-220-000
42	Filter Body	1	664-591-000

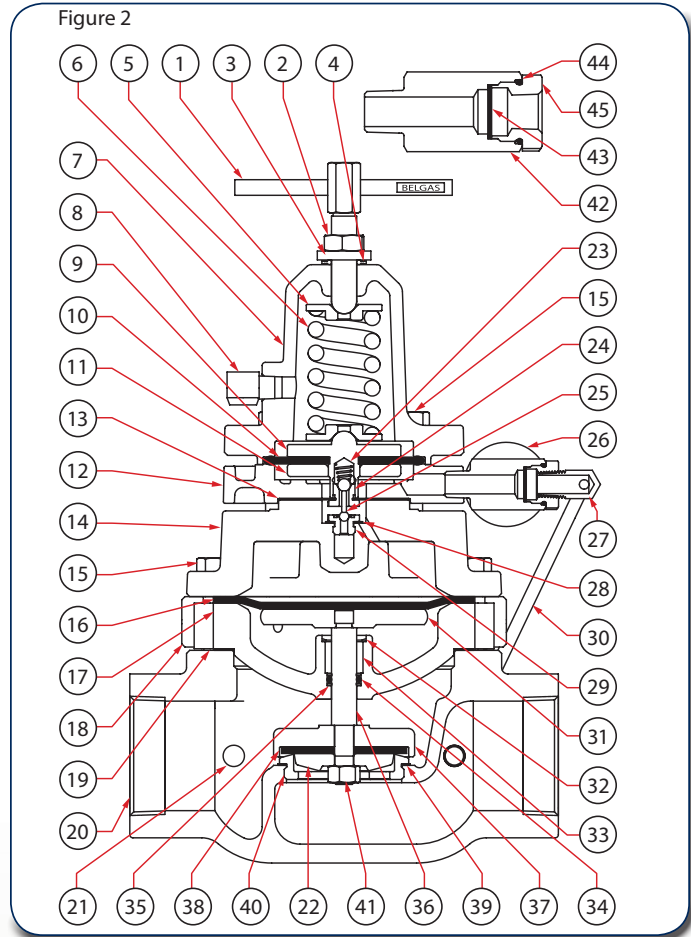

Item	Description	Qty.	Part Number
43	Filter Screen	3	647-030-000
44	O-ring	Nitrile	649-000-008
		Fluorocarbon	649-000-211
		FEPM	649-351-008
		HSN	649-437-003
45	Filter Cap	1	610-104-000

Elastomer Repair Kits	Qty.	Part Number
Repair Kit	Nitrile	971-P53-000
	Fluorocarbon	971-P53-001
	HSN	971-P53-002
	FEPM	971-P53-003

Torque Table		
Item	Description	Torque (in. - lbs.)
15	Bonnet & Body Screws	150 (Bonnet) 150 (Body)
24	Pilot Seat	100
29	Bleed Orifice	100
41	Locknut	150



**Trusted.
Proven.
Better.**

8019 Ohio River Blvd.
Newell, WV 26050
Toll Free: 800-727-5646
sales@belgas.net
www.BelGASCP.com

2221 SE 69th Street
Oklahoma City, OK 73149
Toll Free: 800-833-3127